

pedante¹

automated length stop

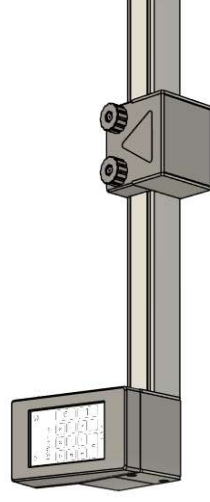

Assembly guide video

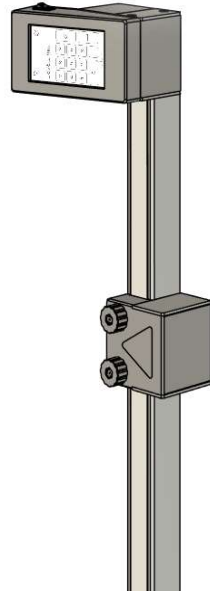
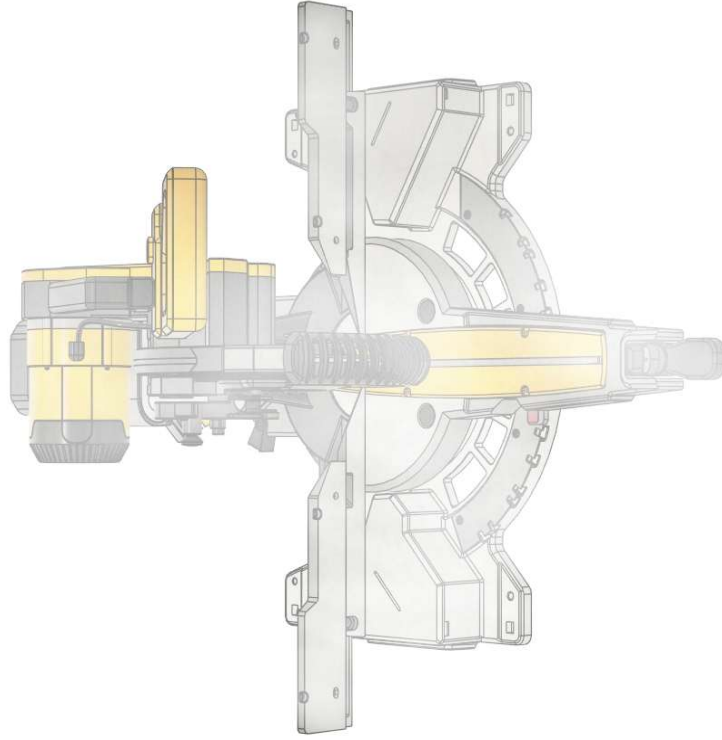

models:
LS-12-U, LS-24-U
LS-36-U, LS-48-U, LS-60-U

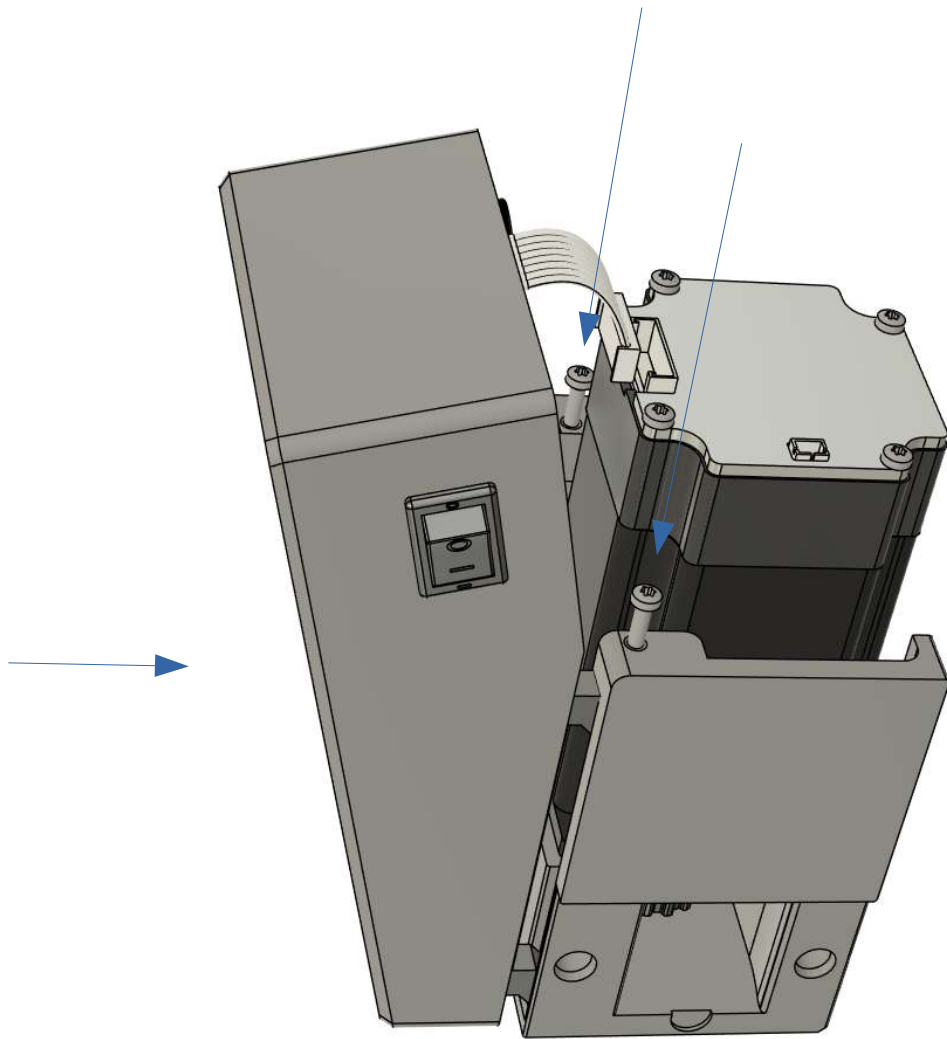

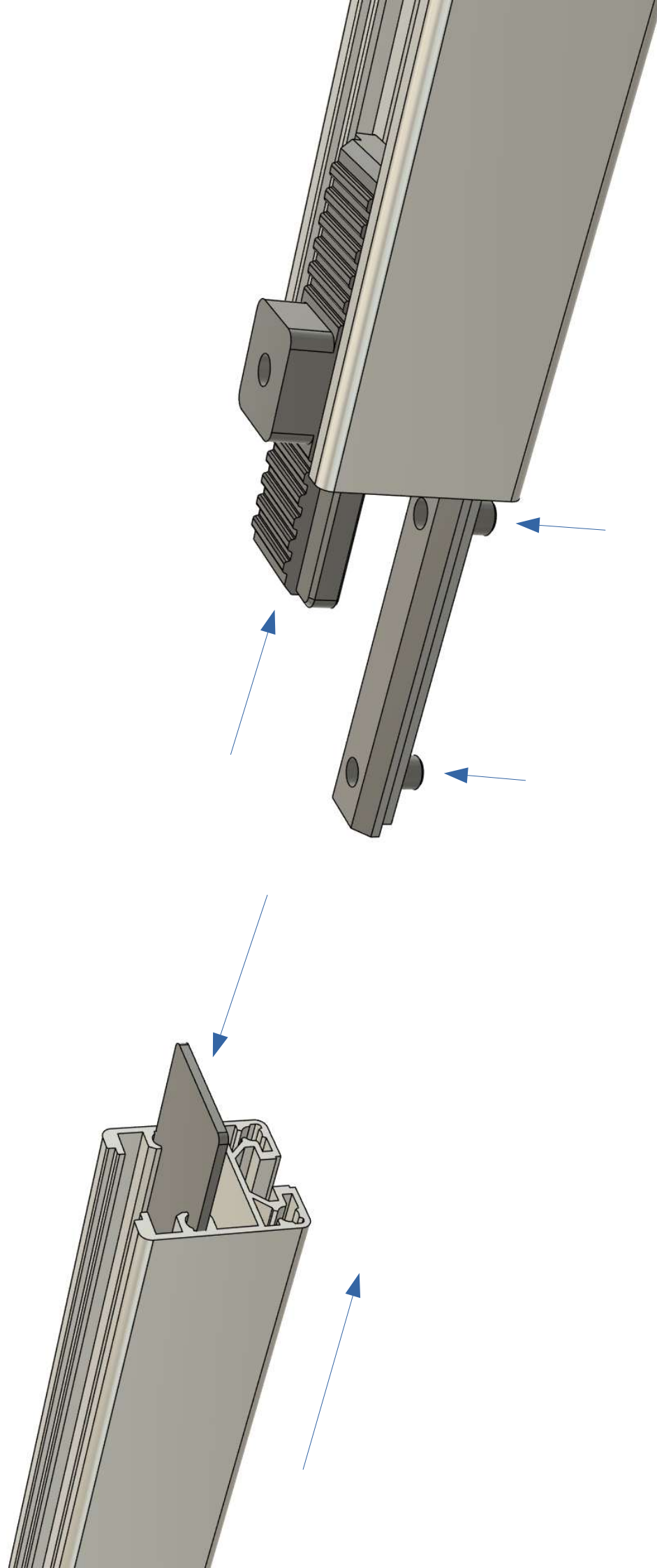

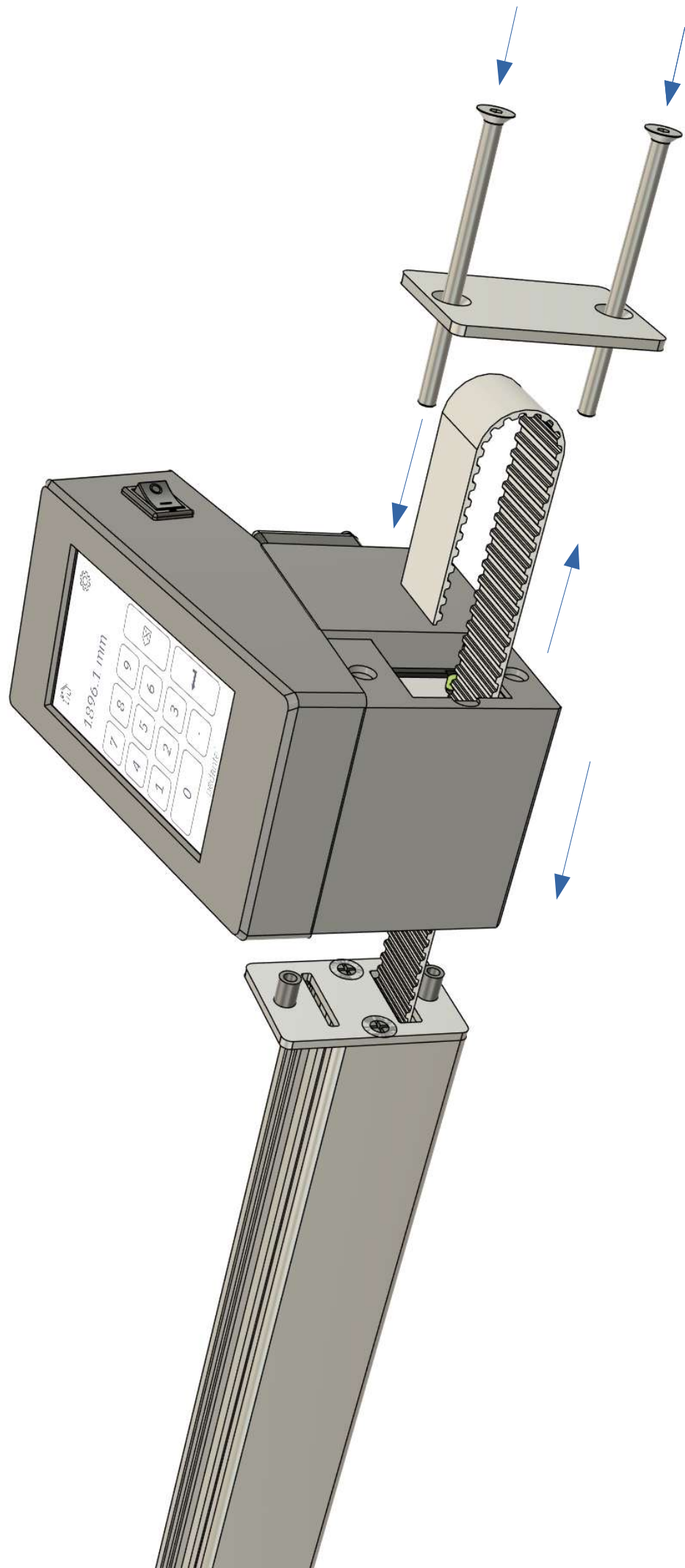

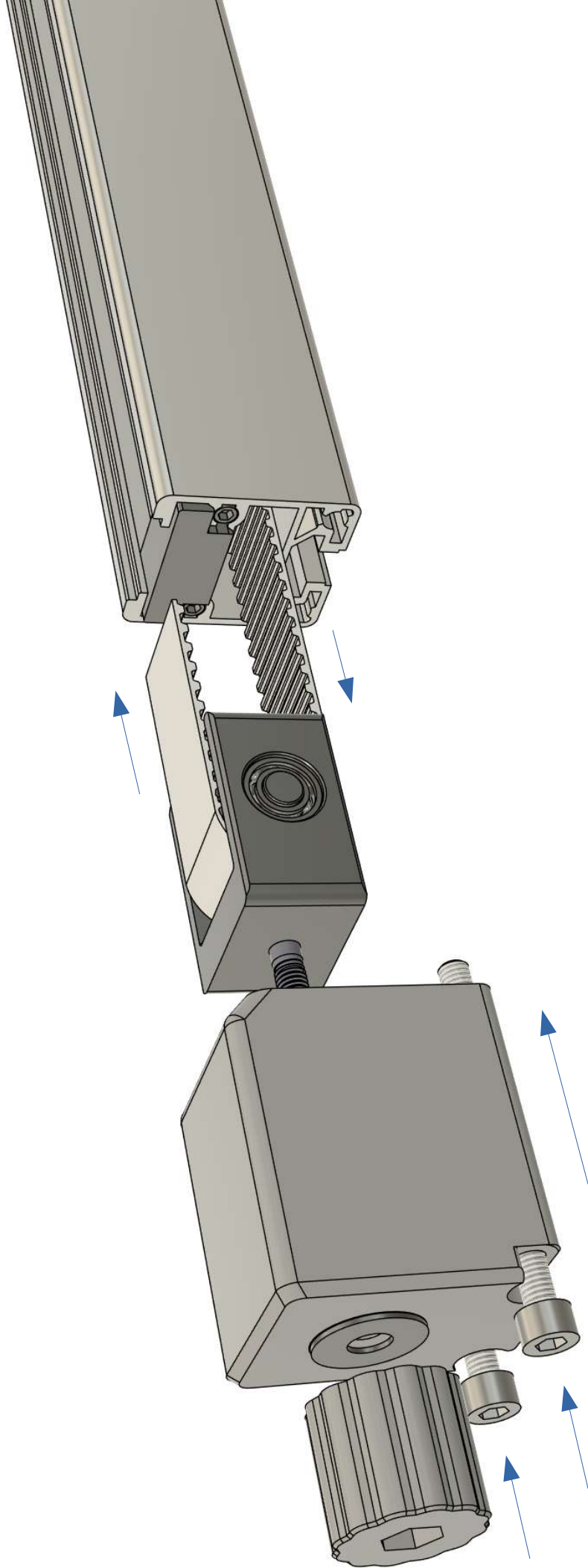

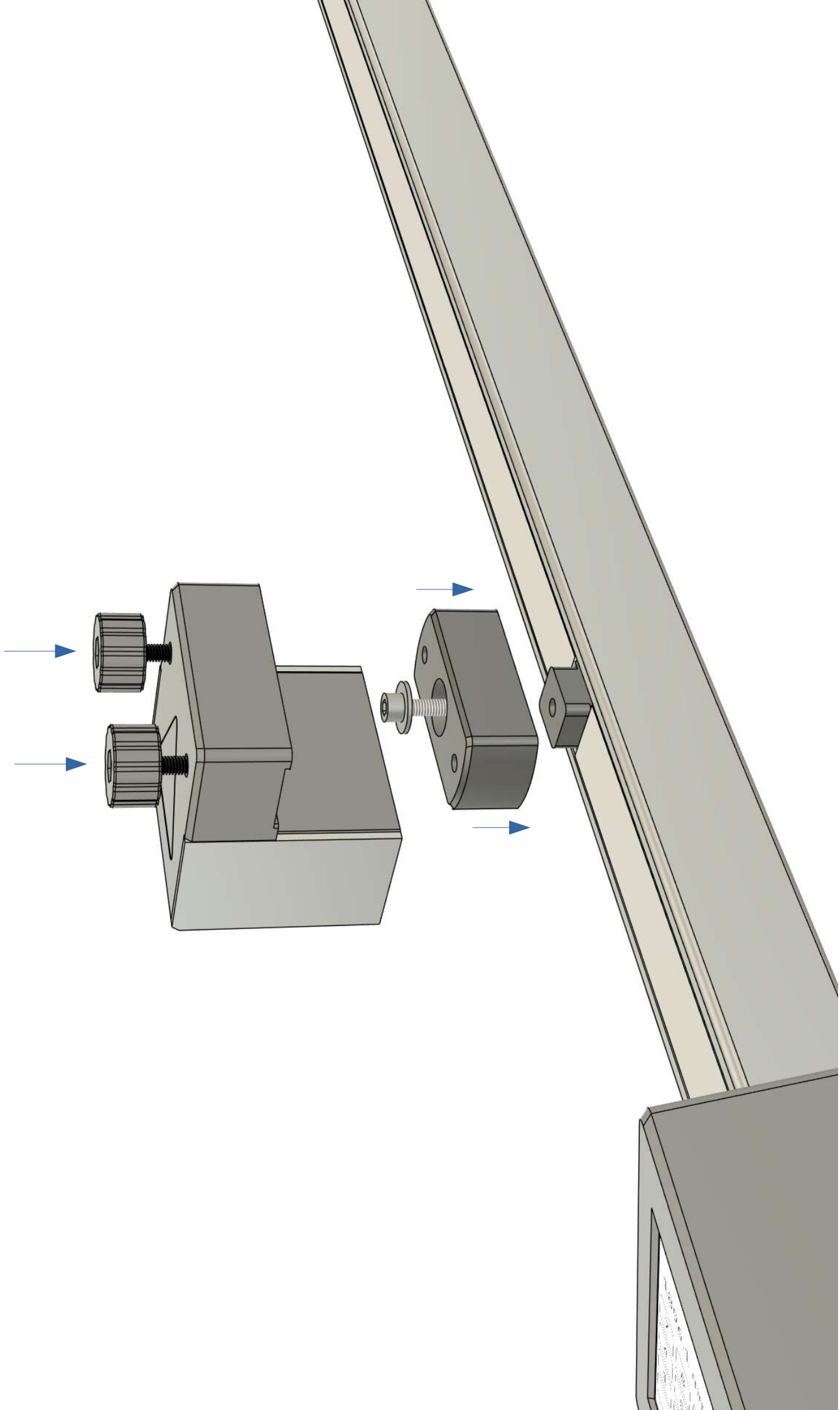

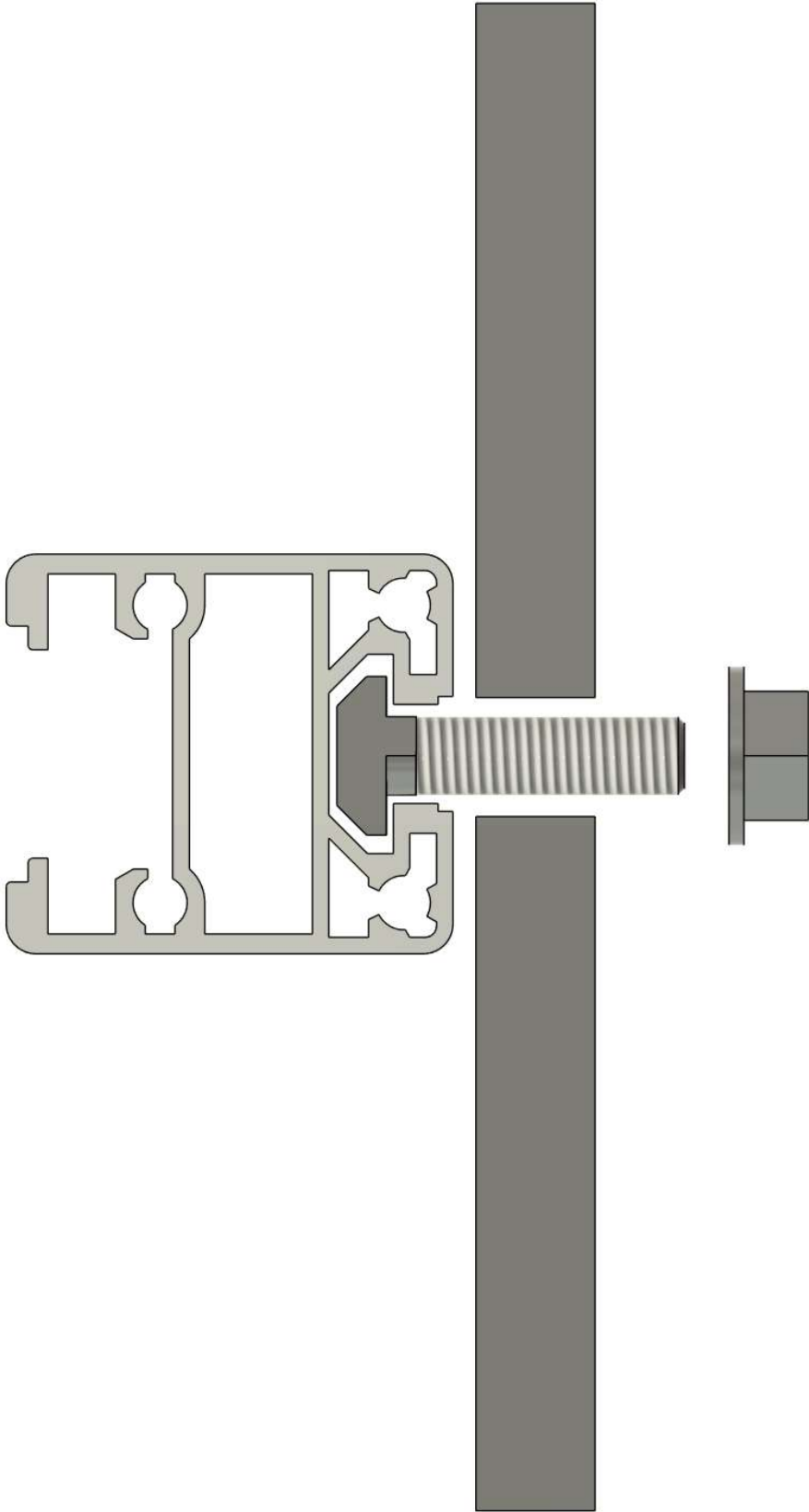



Please Read Safety Instructions and Usage Guidelines

Failure to follow safety instructions and guidelines can result in fire, electrical shock, or serious injury.

Please pay attention to the images at the beginning of the user manual.

General warnings



- **Keep Body Parts Away During Operation**

Maintain a safe distance from the equipment while it is in motion to avoid the risk of entrapment. There is a risk of pinching or crushing injuries.



- **Electrical Safety:** Ensure that the equipment is connected to the correct voltage and that all electrical connections are secure and compliant with safety standards.
- **Avoid Overloading:** Do not exceed the specified load capacity of the equipment to prevent damage or malfunction.
- **Keep Dry:** Avoid exposing the equipment to water or moisture to prevent electrical hazards.
- **Proper Use:** Use the equipment only for its intended purpose and in accordance with the manufacturer's guidelines.
- **Regular Maintenance:** Perform regular maintenance and inspections to ensure the equipment operates correctly and safely.
- **Emergency Procedures:** Familiarize yourself with emergency stop procedures and ensure that they are easily accessible during operation.
- **Protective Gear:** Wear appropriate personal protective equipment (PPE) as required for the specific tasks being performed.

→ **Do not use the automatic stop for pushing materials.**

→ **Continuous pressure on the stop block may cause the equipment to overheat.**

→ **A strong magnetic field near the equipment can cause operational disturbances.**

→ **Do not compress, bend, or otherwise mechanically damage any parts of the equipment, including the aluminum profile.**

→ **Avoid mechanical impacts on the stop block.**

Equipment Description

- The automatic length stop is an electronically controlled device designed as an auxiliary tool for material cutting or drilling operations.
- The equipment consists of an aluminum profile and a carriage that moves along the profile, on which the stop block is mounted. The carriage is driven by a stepper motor and a timing belt.
- The control unit includes a touchscreen and stepper motor control with an integrated microcontroller. The control unit requires an external power supply of DC 24V 3.0A, with a 2.5/5.5 mm socket.
- The equipment is operated via a touchscreen interface. Power is controlled by a mechanical ON/OFF switch located on the side of the control unit housing.

Technical Data

Models		LS-12-U	LS-24-U	LS-36-U	LS-48-U	LS-60-U
Voltage		DC 24 V				
Max current	A	3.0				
Power	W	72				
Working range	mm	1040	2220	3400	4580	5760
Total length	mm	1340	2520	3700	4880	6060
Positioning accuracy		±0.2 mm (after calibration)				
Weight	kg	3.8	5.7	7.6	9.5	11.4
Electrical protection class		 / III				

First Power-On – Automatic Self-Setup (Mandatory)

Important:

Before powering on the unit for the first time, the system **must be fully assembled**, including:

- Aluminum profile
- Timing belt
- Stop block (carriage)
- Control unit firmly mounted

What Happens on First Power-On

On the very first power-up, the system automatically runs a **self-setup program**. During this process, the unit:

- Detects whether the system is **left-hand or right-hand configuration**
- Detects the **working length** of the installed profile
- Stores these parameters internally

The carriage will move automatically and may travel the full available range. This is normal.

Do not touch the carriage or interrupt power during this process.

When the procedure is complete, the system proceeds automatically to normal operation.

Daily Positioning (Homing)

Homing is required **each time the equipment is powered on** to ensure positioning accuracy.

Homing Method

The Universal models use **sensorless homing with a mechanical hard stop**. No physical end switch is used.

Homing Procedure

1. Power On the Equipment

After power-up, a home icon appears in the center of the screen.

2. Start Homing

Press the home icon.

A short beep sounds, and the carriage begins moving toward the control unit.

3. Hard Stop Detection

The carriage gently moves against the mechanical end stop.

Motor load and encoder feedback are used to detect the stop position.

4. Precision Approach

The carriage moves slightly away, then slowly returns toward the hard stop for precise reference positioning.

5. Completion

A long beep confirms successful homing.

The main screen appears, showing the current stop position.



Do not block or resist carriage movement during homing or self-setup.

Calibration (Reference Zero Setting)

Calibration is required:

- After initial installation
- After mechanical changes
- After blade, tool, or reference point changes

Calibration sets the **reference zero** (saw blade, drill bit, cutter, etc.).

Calibration Procedure

1. Measure the Actual Distance

Measure the distance between the stop block and the reference point.
Alternatively, cut a workpiece and measure the result.

2. Enter the Measurement

Enter the measured value on the touchscreen.

3. Confirm Calibration

Press and hold the **calibration button (gear icon)** for 4 seconds.

4. Confirmation

A long beep sounds and the display shows:
“**Calibration OK**”

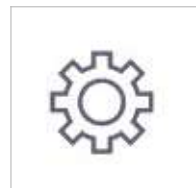

Operation

Entering a Position

- Enter the desired value using the numeric keypad.
- Correct input using backspace if needed.
- Press **Enter** to confirm.



If the entered value is outside the allowed range, the display shows:
>minPosition - maxPosition<

Movement

- After pressing Enter, the carriage moves to the target position.
- Motion can be stopped at any time using the emergency stop (see below) or by switching power off.

Backlash Compensation

If the target position is away from the control unit:

- The carriage moves approximately **20 mm past** the target
- Then approaches the position from the same direction every time

This ensures repeatable accuracy.

Smart Position Guard

A high-resolution encoder continuously monitors position.

If deviation exceeds **0.1 mm**, the system automatically corrects the position.

Emergency Stop

Activation

When the carriage is moving, a red “**Emergency Stop**” indicator appears on a yellow background.

- Touch **anywhere on the screen** to stop movement immediately.

Behavior

- Motor drive is disabled instantly
- Short warning beeps sound
- Display shows:
“**ALARM!! Motor stopped**”



Restart

To resume normal operation:

1. Switch the unit OFF
2. Switch the unit ON
3. Perform homing

Hidden / Advanced Functions

Unit Change (mm / inch)

- Press and **hold the unit indicator** (“mm” or “in”) on the display
- The measurement system toggles between millimeters and inches

Timing Belt Calibration (Advanced – experienced users)

Used to compensate for belt pitch tolerances over long distances.

Procedure:

1. Perform **Homing**
2. Perform **Standard Calibration** (Set zero using the shortest possible distance)
3. Move to a **long distance**
4. Measure the actual distance
5. Enter the measured value
6. Press and **hold the hidden button**
(empty area between the Home and Calibration buttons)



Confirmation:

- Long beep
- Display message: “**Belt calibrated**”

The process can be repeated if needed.

Incorrect calibration may reduce accuracy.

System Reset / Re-Initialization

Used when:

- Changing left/right configuration
- Changing profile length
- Reinstalling the system

Procedure:

1. Press and hold the **“pedante”** logo on the screen
2. Hold until a long beep sounds
3. Display shows: **“Restart”**
4. Switch the unit OFF
5. Switch the unit ON

The **automatic self-setup program** will run again.

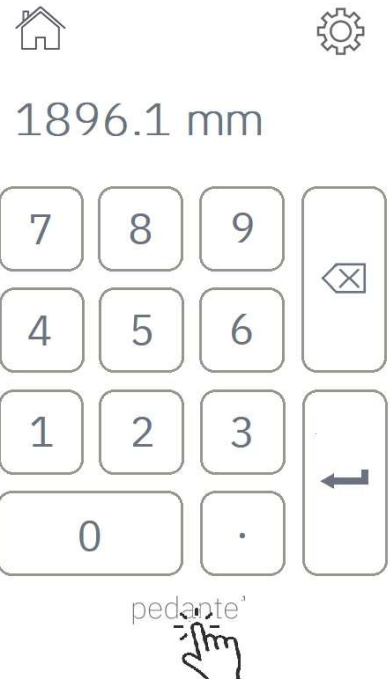

Maintenance

Regular cleaning is required, especially under the timing belt.

Maintenance Procedure

1. Disconnect power
2. Loosen belt using the tensioning knob
3. Remove the stop block by lifting upward
4. Unscrew the belt clamp and release the belt
5. Vacuum dust and debris from the profile
6. Reinstall and tension the belt
7. Perform homing and calibration if required

Possible Malfunctions

- The system includes overload protection
- If carriage motion is blocked, the motor may emit a noise due to skipped microsteps
- This indicates excessive resistance

Action:

- Remove obstructions, and ensure free carriage movement
- Check belt alignment and cleanliness

General Power Tool Safety Warnings



WARNING

Read all safety warnings and all instructions. Failure to follow the warnings and instructions may result in electric shock, fire and/or serious injury.

Save all warnings and instructions for future reference.

The term "power tool" in the warnings refers to your mains-operated (corded) power tool or battery-operated (cordless) power tool.

Work area safety

- **Keep work area clean and well lit. Cluttered or dark areas invite accidents.**
- **Do not operate power tools in explosive atmospheres, such as in the presence of flammable liquids, gases or dust.** Power tools create sparks which may ignite the dust or fumes.
- **Keep children and bystanders away while operating a power tool.** Distractions can cause you to lose control.

Electrical safety

- **Power tool plugs must match the outlet. Never modify the plug in any way. Do not use any adapter plugs with earthed (grounded) power tools.** Unmodified plugs and matching outlets will reduce risk of electric shock.
- **Avoid body contact with earthed or grounded surfaces, such as pipes, radiators, ranges and refrigerators.** There is an increased risk of electric shock if your body is earthed or grounded.
- **Do not expose power tools to rain or wet conditions.** Water entering a power tool will increase the risk of electric shock.
- **Do not abuse the cord. Never use the cord for carrying, pulling or unplugging the power tool. Keep cord away from heat, oil, sharp edges or moving parts.** Damaged or entangled cords increase the risk of electric shock.
- **When operating a power tool outdoors, use an extension cord suitable for outdoor use.** Use of a cord suitable for outdoor use reduces the risk of electric shock..
- **If operating a power tool in a damp location is unavoidable, use a residual current device (RCD) protected supply.** Use of an RCD reduces the risk of electric shock.

Personal safety

- **Stay alert, watch what you are doing and use common sense when operating a power tool. Do not use a power tool while you are tired or under the influence of drugs, alcohol or medication.** A moment of inattention while operating power tools may result in serious personal injury.

- **Use personal protective equipment. Always wear eye protection.** Protective equipment such as dust mask, non-skid safety shoes, hard hat, or hearing protection used for appropriate conditions will reduce personal injuries.
- **Prevent unintentional starting. Ensure the switch is in the off-position before connecting to power source and/or battery pack, picking up or carrying the tool.** Carrying power tools with your finger on the switch or energising power tools that have the switch on invites accidents.
- **Remove any adjusting key or wrench before turning the power tool on.** A wrench or a key left attached to a rotating part of the power tool may result in personal injury.
- **Do not overreach. Keep proper footing and balance at all times.** This enables better control of the power tool in unexpected situations.
- **Dress properly. Do not wear loose clothing or jewellery. Keep your hair, clothing and gloves away from moving parts.** Loose clothes, jewellery or long hair can be caught in moving parts.
- **If devices are provided for the connection of dust extraction and collection facilities, ensure these are connected and properly used.** Use of dust collection can reduce dust-related hazards.

Power tool use and care

- **Do not force the power tool. Use the correct power tool for your application.** The correct power tool will do the job better and safer at the rate for which it was designed.
- **Do not use the power tool if the switch does not turn it on and off.** Any power tool that cannot be controlled with the switch is dangerous and must be repaired.
- **Disconnect the plug from the power source and/or the battery pack from the power tool before making any adjustments, changing accessories, or storing power tools.** Such preventive safety measures reduce the risk of starting the power tool accidentally.
- **Store idle power tools out of the reach of children and do not allow persons unfamiliar with the power tool or these instructions to operate the power tool.** Power tools are dangerous in the hands of untrained users.
- **Maintain power tools. Check for misalignment or binding of moving parts, breakage of parts and any other condition that may affect the power tool's operation. If damaged, have the power tool repaired before use.** Many accidents are caused by poorly maintained power tools.
- **Keep cutting tools sharp and clean.** Properly maintained cutting tools with sharp cutting edges are less likely to bind and are easier to control.
- **Use the power tool, accessories and tool bits etc. in accordance with these instructions, taking into account the working conditions and the work to be performed.** Use of the power tool for operations different from those intended could result in a hazardous situation.

Service

- **Have your power tool serviced by a qualified repair person using only identical replacement parts.** This will ensure that the safety of the power tool is maintained.

Customer service

The customer service team will assist you with questions regarding product repair and maintenance, as well as spare parts. Additional information about operation and spare parts can be found on our website:

www.pedante.eu

When requesting consultations or ordering spare parts, please provide the product serial number, which is indicated on the product's nameplate.

Pedante SIA

**Maza Gaismas 1,
Salaspils, LV 2169, Latvia**

Tel.: + 371 22845678

E-mail: info@pedante.eu

Disposal of Used Electrical Tools

Electrical tools, their accessories, and packaging materials should be disposed of through recycling in an environmentally friendly manner.



Do not discard electrical tools in household waste bins!

Only for EU countries.

According to the European Directive 2012/19/EU on Waste Electrical and Electronic Equipment and its implementation into national law, chargers that are no longer usable must be collected separately and disposed of in an environmentally friendly manner.

If disposed incorrectly, waste electrical and electronic equipment may have harmful effects on the environment and human health, due to the potential presence of hazardous substances.